

# Uniden®

## **BW4501 Series** **4.3" LCD Portable Wireless** **Baby Monitoring System**

---

For more exciting new products please visit our website:  
Australia: [www.uniden.com.au](http://www.uniden.com.au)

---

# OWNER'S MANUAL

# IMPORTANT SAFETY INSTRUCTIONS

This manual contains important information about this product's operation. If you are installing this product for others, you must leave this manual or a copy with the end user.

When using your equipment, always follow basic safety precautions to reduce the risk of fire, electric shock and injury to persons, including the following:

- **This equipment is NOT waterproof.** DO NOT expose it to rain or moisture.
- DO NOT immerse any part of the product in water. Do not use this product near water, e.g., near a bathtub, wash bowl, kitchen sink or laundry tub, in a wet basement or near a swimming pool.
- To avoid any risk of electric shock from lightning, avoid handling any electronic devices during an electrical storm.
- Use only the power cord and/or batteries indicated in this manual. Never dispose of any batteries in a fire: they may explode. Check with local codes for possible special disposal instructions.
- Never tug or pull on any power cord: be sure to leave some slack in the cord when placing your equipment, and always use the plug to unplug cord from the wall outlet.
- Never leave power cords where they can become crushed, cut, or frayed; when running power cords, avoid letting them rub against any sharp edges or lie across any high traffic areas where people might trip over them.
- Do not use the device if the adaptor cords or plugs have been damaged, the unit has been exposed to liquids, or the unit has been dropped or is damaged.

## MAINTAINING YOUR SYSTEM

### Monitor

Keep the screen clean by wiping it with a microfiber cloth to remove fingerprints, dust, etc.

### Camera

When dust and grime builds up on the camera lens and glass, it affects the camera's "vision." Use a microfiber cloth to regularly clean the cameras or when night vision video is cloudy or unclear.

## **Warning to Parents and Other Users**

Failure to follow these warnings and the assembly instructions could result in serious injury or death. This product is not designed or intended for use as a medical monitor, nor should this product be used as a substitution for medical or parental supervision. Always be sure that both the transmitter and receiver are working properly, and are within range of each other.

**STRANGULATION HAZARD.** Keep the adaptor cords out of the reach of children.

## **WARNING: KEEP OUT OF THE REACH OF CHILDREN.**

Allow for proper ventilation when units are in use. Do not cover the camera or receiver with any object such as a blanket. Do not place it in a drawer or in any location which would muffle the sound or interfere with the normal flow of air.

---

### ***SAVE THESE INSTRUCTIONS!***

---

## **For best results**

To avoid damage to your equipment, follow these simple precautions:

- Do not drop, puncture or disassemble any part of the equipment. There are no user-serviceable parts inside.
- Do not expose the equipment to high temperatures, and avoid leaving the equipment in direct sunlight for more than a few minutes. Heat can damage the case or electrical parts.
- Do not place heavy items on top of the equipment or expose the equipment to heavy pressure.
- Remove the power adaptor during long periods between usages.
- Clean only with a dry cloth.

***Failure to follow the instructions in this operating manual will void the warranty. Uniden assumes no liability for damages to property or injury to persons caused by improper handling or failure to comply with these safety instructions.***

# CONTENTS

<b>WHAT'S IN THE BOX?</b> .....	<b>5</b>
<b>GETTING STARTED</b> .....	<b>6</b>
<b>INSTALLATION</b> .....	<b>10</b>
MONITOR INSTALLATION .....	10
CAMERA INSTALLATION .....	10
<b>PAIRING</b> .....	<b>12</b>
<b>PAIRING TWO CAMERAS</b> .....	<b>13</b>
<b>USING THE BABY MONITOR</b> .....	<b>14</b>
VOLUME .....	14
MONITOR BRIGHTNESS .....	14
PHOTO .....	14
VIDEO .....	14
GALLERY .....	15
LULLABIES .....	15
STATUS LIGHT/NIGHT LIGHT .....	16
<b>SYSTEM MENUS</b> .....	<b>16</b>
FEEDING REMINDER .....	16
TEMPERATURE AND HUMIDITY DETECTION .....	17
SMART CARE .....	18
SLEEP MODE .....	19
DATE AND TIME .....	20
CAMERA LIGHT (STATUS LIGHT/NIGHT LIGHT) .....	20
SD CARD .....	21
WALLPAPER .....	21
LANGUAGE .....	21
FACTORY RESET .....	21
DEVICE INFORMATION .....	22
BATTERY INFORMATION .....	22
<b>TROUBLESHOOTING</b> .....	<b>23</b>
<b>SPECIFICATION</b> .....	<b>24</b>
<b>TWO-YEAR LIMITED WARRANTY</b> .....	<b>26</b>

# WHAT'S IN THE BOX?

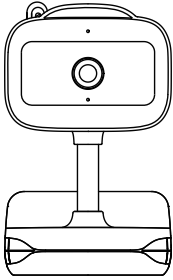

BW4501  
Camera\*

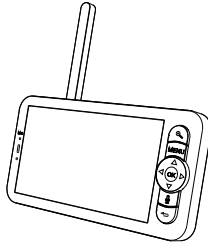

BW4501  
Monitor

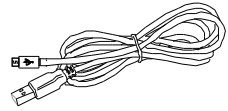

USB-C Cable\*

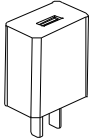

AC Adaptor\*

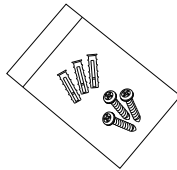

Screws & Anchors

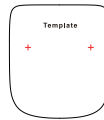

Mounting  
Template



Reset Pin

\* Refer to the table below.

Model Name	4.3" Monitor	Camera	Adaptors
BW4501	1	1	2 x USB-C Cable 2 x AC Adaptor

\* Additional 1 Camera BW450 can be added to BW4501.

- If any item is missing or damaged, contact your place of purchase immediately.  
**Never use damaged products!**
- Need help? Get answers at our website:  
**[www.uniden.com.au](http://www.uniden.com.au)** for Australian model

All trademarks are registered trademarks of their respective owners.

# GETTING STARTED

## Camera

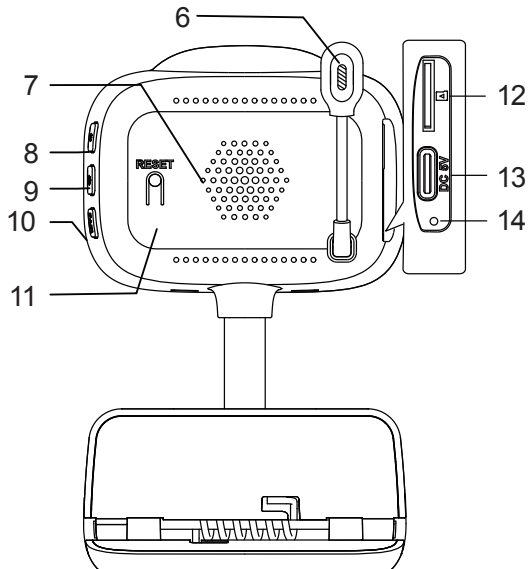
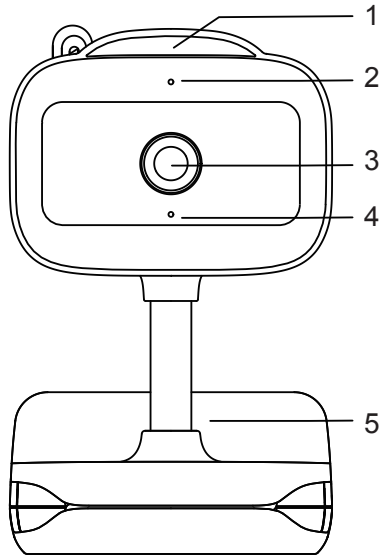

Item	What it does
1	LED night light bars.
2	<p><b>Status Light:</b>  Solid Red: Camera is malfunction.  Slow Blinking Red: Waiting for the connection with the pairing monitor. Refer to Item 10.  Fast Blinking Red: Pairing with the monitor/ Fail to connect to the monitor.  Solid Blue: Camera connected to the monitor.</p>
3	<b>Lens:</b> Camera lens.
4	<b>Microphone:</b> Receives sounds for the area near the camera, and transmits sound from the camera to the monitor.
5	<b>Mounting Clip:</b> This fastener can attach the camera to shelves or ledges.
6	<b>Temperature and humidity sensor:</b> Detects the temperature and humidity of the environment.
7	<b>Speaker:</b> Produces the sound transmitted from the monitor.
8	<b>Power:</b> Press and hold to turn the camera ON or OFF.
9	<b>Night Light:</b> Press to turn the night light on or off.
10	<p><b>Pair:</b> Press and hold until the prompt tone is heard to start pairing.  <b>Video Call:</b> Press to activate video call feature through the app. Camera requires internet connection.</p>
11	<b>Reset:</b> Press and hold for 5 seconds to reset the camera (reset to factory defaults).
12	<b>MicroSD Card Slot:</b> Camera SD Card slot is only for firmware updates.
13	<b>USB-C Port:</b> Connects the USB cable to the camera.
14	<p><b>Charging LED:</b>  Orange = Charging  Green = Fully charged</p>

# Monitor

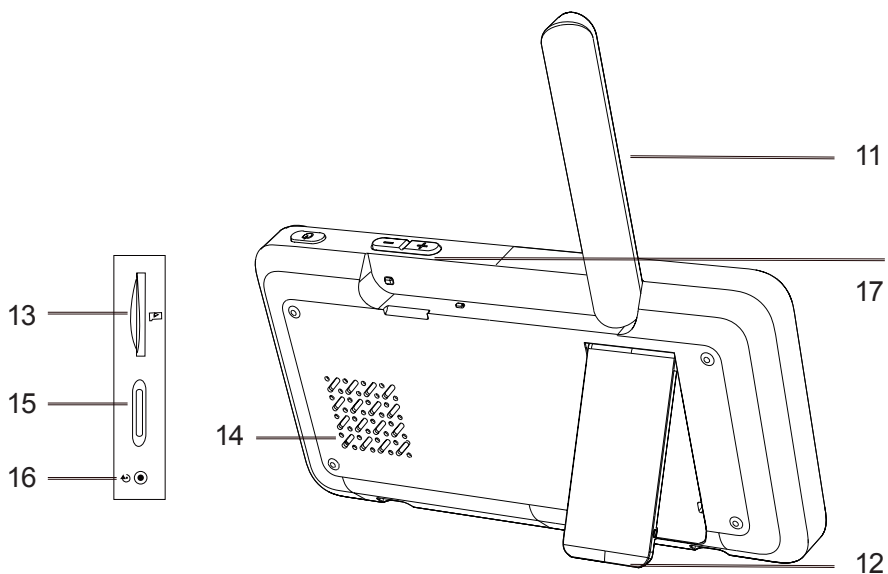
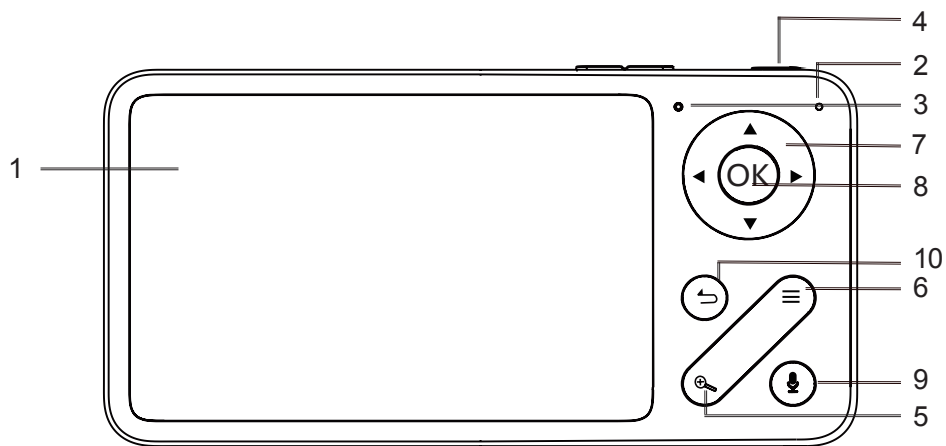



Item	What it does
1	4.3 inch LCD screen.
2	<b>Microphone:</b> Capture sounds and transmits it to the camera.
3	<b>Status Light:</b> Orange: Charging, Working and Sleep. Black: Power off. If the monitor unplugged from the power, this LED turns off.
4	<b>POWER:</b> Press and hold 5 seconds to turns the monitor on and off. Switch cameras when dual screen.
5	<b>ZOOM:</b> Single View Mode: Press to zoom the image in 1X, 2X or 4X in single view mode. (Dual View Mode: Press the zoom key to enter camera selection mode to select between channel 1 and channel 2.)
6	<b>MENU:</b> Press to display the menu options. Press and hold to enter settings interface.
7	<b>Up/Down/Left/Right:</b> Menu: Navigate menu and adjust the settings.
8	<b>OK:</b> Press to confirm selection. (Dual View Mode: Press to enter the full screen after channel selection.)
9	<b>Call to TALK:</b> Activate Intercom function.
10	<b>Return:</b> Press to return/back one level. Press and hold to stop playing lullaby.
11	<b>Antenna:</b> Receives video and audio signals from the camera(s).
12	<b>Stand</b>
13	<b>MicroSD Card Slot:</b> Insert microSD card (up to 128GB) to record video.
14	<b>Speaker</b>
15	<b>USB-C Port:</b> Connects the USB cable to the monitor.
16	<b>Reset:</b> Insert and release the reset pin to reset the monitor.
17	<b>Volume:</b> Adjust volume using + or -.

# INSTALLATION

## MONITOR INSTALLATION

Place the monitor in a location with clear reception from your camera(s). If you are using the monitor as a stand-alone unit, flip out the stand on the back of the monitor and extend the antenna.

1. Insert one end of the USB-C cable to the USB-C port on the side of the monitor.
2. Connect the other end of the USB cable into the USB power adaptor.
3. Connect the USB power adaptor into a 240 volt AC (standard indoor) power outlet.

Press and hold the **POWER** button to turn the unit on or off. Let the monitor charge for 6 hours prior to first time use so the built-in rechargeable monitor battery is fully charged. **DO NOT** remove the USB cable from the monitor during the initial charge process. After the initial charge, recharge the monitor as needed.

🔧 **We recommend that the device should be fully charged once every three months with the monitor switched off in order to prolong the device's battery life.**

## CAMERA INSTALLATION

The camera and the mounting clip are a complete unit. The camera can be placed on a shelf or the included mounting clip has two slots that fit over screws to mount or clip the camera on ledges and shelves the unit on the wall.

### Placement Considerations

- The camera included with your monitor is **NOT** weatherproof; it is an indoor camera.
- The clearest line-of-sight between the camera and monitor is best. Walls, especially brick and concrete, can affect reception quality.
- Avoid having a direct light source in view of the camera (ceiling or floor lamps).
- Carefully plan where and how the camera will be positioned, and where you will route the cable that connects the camera to the power adaptor.
- When you are positioning the camera, bring the monitor along; it's much easier to get the camera into the right position when you have the display handy. Check the image on the monitor before you install the camera.

🔧 **You can install a maximum of 2 cameras. When adding cameras that were not included in the original box, you will need to pair the cameras with the monitor.**

## Wall Mount

The camera mounting clip has two slots that fit over screws to mount the unit on the wall.

1. Install the screws to the wall according to the position of the drill template. Do not tighten the screws to the end, as you need to leave a gap for hanging the camera.
2. Place the mounting clip over the installed screws and push it downwards, locking it into place.
3. Adjust the camera as needed.

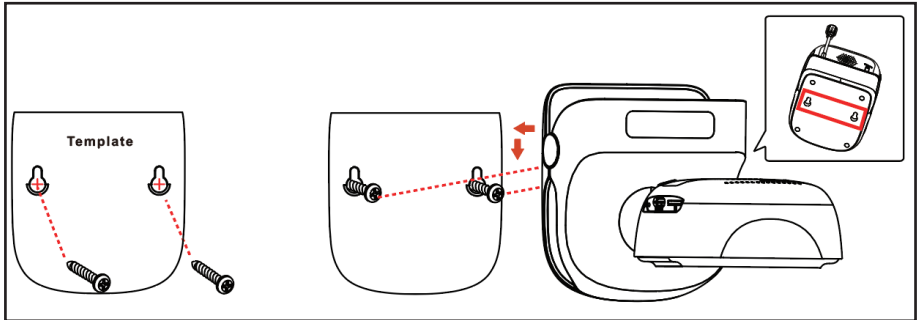

## Clip Mount

Clip the camera on ledges and shelves.

1. Press the mounting clip as shown.
2. Place the unit over the mounting surface and release.
3. Adjust the camera as needed.

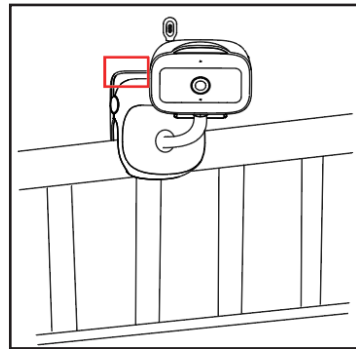

## Powering the Camera

1. Insert one end of the USB-C cable to the USB-C port on the camera (on the side of the camera).
2. Connect the other end of the USB cable into the USB power adaptor.
3. Connect the USB power adaptor into a 240 volt AC (standard indoor) power outlet.
4. Switch on the plug and allow the camera to power up. The pairing indicator will flash momentarily.

# PAIRING

## Viewing the Camera on Monitor

After the camera and the monitor are powered on, the camera will connect to the monitor automatically. The camera(s) and the monitor are already paired from the factory. The viewing range is limited to no more than 200m in line of sight. Other factors such as house walls, layout and electronic devices will affect the transmission range.

If the camera is not paired to the monitor or additional camera is added, please pair the camera to the monitor.

### Pairing the camera to the monitor:

1. Press the **Menu** button on the monitor, and select  > **Camera**.

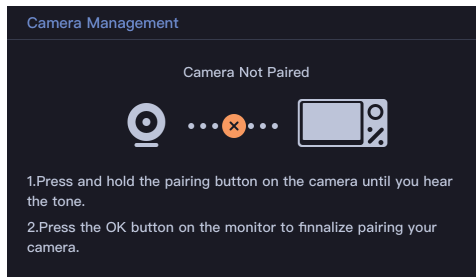

2. Press and hold the pairing button on the camera until you hear the prompt tone.

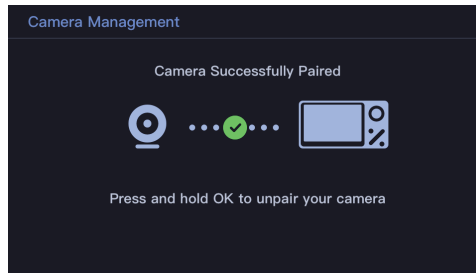

3. Press **OK** button on the display screen to start pairing.

### Unpair the camera from the monitor:

1. Press the **Menu** button on the monitor, and select  > **Camera**.
2. Press and hold **OK** button on the monitor to unpair the camera.

# PAIRING TWO CAMERAS

The BW4501 baby monitor supports up to two camera connections and able to display two camera feeds at the same time.

To set parameters or enable functions of one of the cameras, you will need to select the camera first.

## Camera Selection:

### 1. Camera:

Press  on the home page to zoom in and zoom out.

### 2. Camera:

Press  on the home page to switch between Camera 1 and Camera 2.

To enjoy one camera view, please press **OK** after selecting the camera.

The below interfaces are for reference only.

In addition, the battery level of the camera appearing on each camera view.

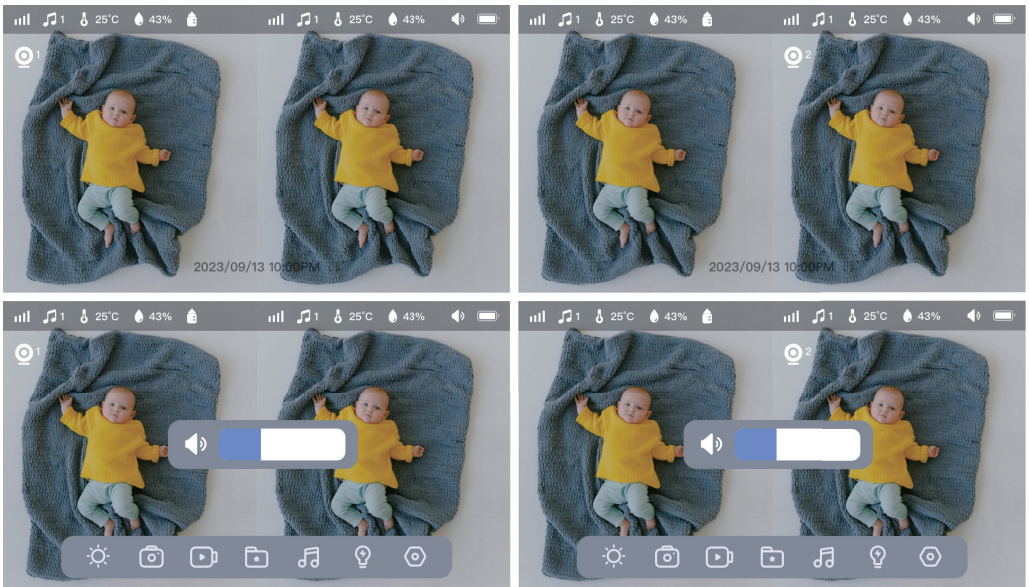

# USING THE BABY MONITOR

## Volume

This option allows you to adjust the volume level for the monitor.

Press +/- button on top right of the monitor to adjust.

## Monitor Brightness

This option allows you to adjust the brightness level for the monitor.

1. Press **Menu** button on the monitor and select .
2. Press UP and DOWN direction buttons to adjust to adjust the monitor brightness.

## Photo

Take a photo to capture an interesting scene of your baby. Please ensure a micro SD Card is inserted to take a photo.

Press **Menu** button on the monitor, select  and press OK to take a photo.

## Video

Manually record video to capture an interesting scene of your baby. Please ensure a micro SD Card is inserted to start recording.

1. Press **Menu** button on the monitor, select  and press OK to start recording
2. Press OK again to manually stop the recording.

## Gallery

Access recorded video and photo in the micro SD Card.

1. Press **Menu** button on the monitor, select  and press OK enter the interface.
2. Select the camera and date, select the photo or video you want to view, and press OK to view photo or playback video.
  - \* For a video, press OK to play or pause in the preview mode.
  - \* Press **Return** button to exit preview or return to main menu.

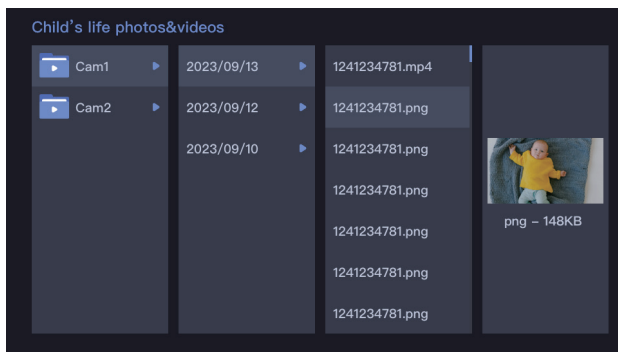

## Lullabies



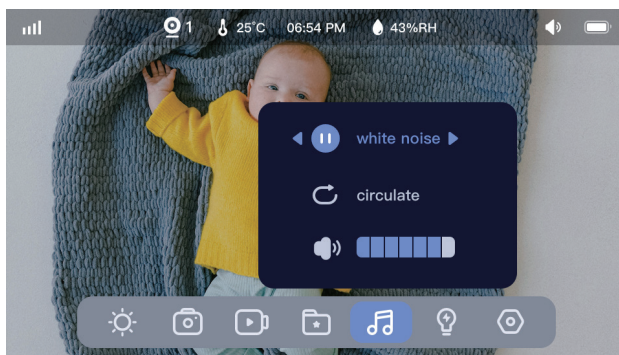

The monitor comes with four lullabies including white noise audio. Play the lullabies to sooth your baby when baby is crying or sleeping.

1. Press **Menu** button on the monitor, select  and press OK enter the interface.
2. You can control play, stop, single, random or circulate the lullabies from the monitor. You may also adjust the camera speaker volume from the monitor.



## Status Light / Night light

This option allows you to switch On/Off the LED indicator and the camera night light and brightness level for the monitor.

1. Status light: Press **Menu** button on the monitor and select  >  On
  2. Night light: Press **Menu** button on the monitor and select  >  On.
- Or press **Menu** button, and select  > **Camera Light** > **Status Light / Night Light**.

## SYSTEM MENU

### Feeding Reminder

Set up a reminder alert to feed your baby, or to feed the baby on scheduled time.

1. Press the **MENU** button on the monitor, and select  > **Feeding Reminder**.
2. Press UP and DOWN direction buttons to select between 4 time options, and press OK to set the alert time.
3. When setting up the feeding time, press LEFT and RIGHT direction buttons to change options between hour, minute, second and On/Off; press UP and DOWN direction buttons to change values or toggle the On/Off switch.
4. Press OK to save settings. You can set up to 4 feeding alert for one day. And when the set time is up, a feeding alert icon will appear on the screen.

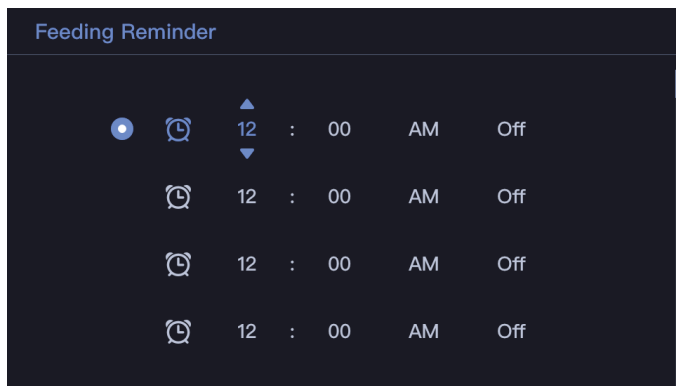



## Temperature and Humidity Detection

The baby monitor is able to provide ambient room temperature and humidity level around the camera as a reference only. If the temperature or humidity falls outside of a preset range, the system alerts you. Temperature and humidity alert range lets you set that range.

1. Press the **MENU** button on the monitor, and select  > **Temperature and Humidity**.
2. Press UP and DOWN direction buttons to select options between temperature range, humidity range and out of range reminder, and press OK to confirm selection.
3. Press LEFT and RIGHT direction buttons to change options, and press UP and DOWN direction buttons to change values and units.
4. Press OK to save settings.
5. For Out of range reminder option, select to turn on or off the alarm when the temperature and humidity are out of range.

 **Please note that the temperature and humidity indicated in this way should be used only as a reference, not as an accurate measurement. For a proper measurement, please use a thermometer or humidity sensor.**

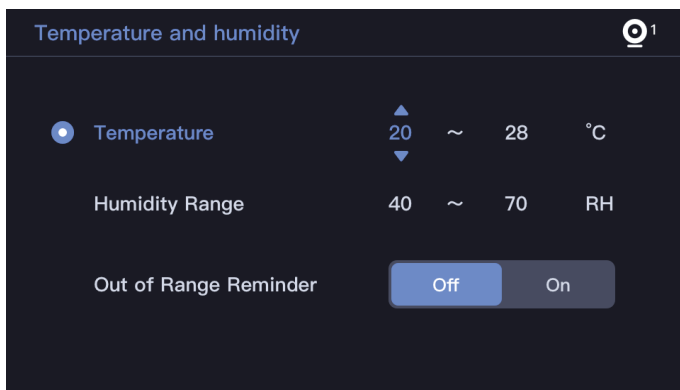

## Smart Care

Motion Detection detects any movement within camera view; Noise Detection identifies the volume of the baby's sound or crying. When any of the detection is above the set threshold, the monitor screen will lit up when it is in sleep mode or the screen is in standby mode.

1. Press the **MENU** button on the monitor, and select  > **Smart Care**.
2. Press UP and DOWN direction buttons to select **Alarm Type** between motion detection, noise detection and alarm volume, and press OK to confirm selection.
3. When setting up any the detection mode, press UP and DOWN direction buttons to adjust sensitivity or turn On/Off.
4. When set up the **Reminder Method**, press UP and DOWN direction buttons to select Icon Reminder, Voice Reminder, and Alarm Volume. Press OK to confirm.
5. To Adjust the alarm volume, press LEFT and RIGHT button.

There will be an alert when the detection is triggered, press OK to stop the alert.

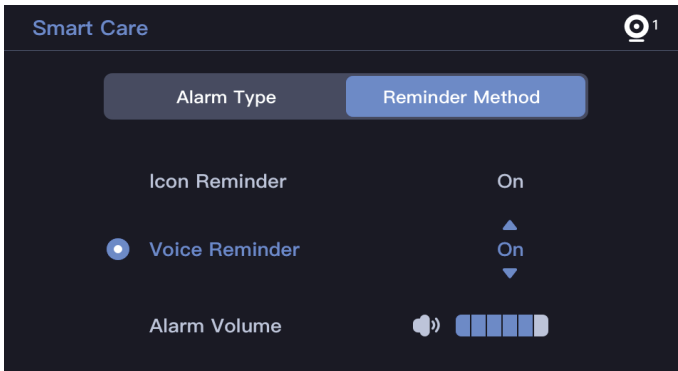
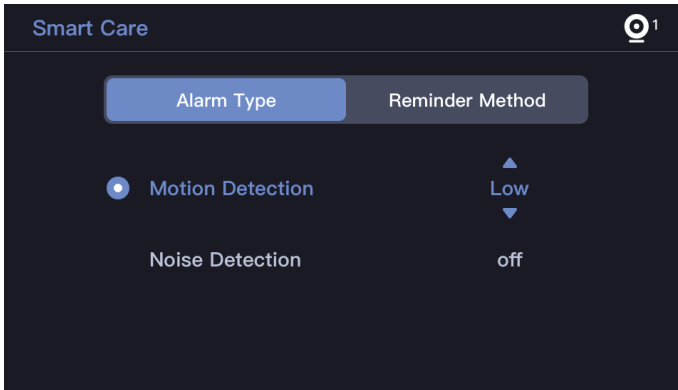

## Sleep Mode

Set the monitor to automatically enter sleep mode according to the length of time. Please make sure to adjust the **Smart Care settings** (page18) according to your needs.

If motion detection or noise detection is on Low/Medium/High, any alert triggered will turn the monitor LCD back on with Reminder Method you selected (Icon, Voice). If none of the motion detection/noise detection is active, press the **POWER** button on the monitor to turn the monitor LCD back on.

**Note:** If you turn OFF both motion detection and noise detection, **Sleep Mode** under **Audio Off** will not be able to hear any sound after the screen turns off. With **Sleep Mode** under **Audio On**, you can only hear sound after the screen turns off.

**Audio Off:** The audio from the camera cannot be heard after the screen is off. Set screen off time in 1 minute, 5 minute, 10 minute, 30 minute, and 60 minute.

**Audio On:** The audio from the camera can still be heard after the screen is off. Set screen off time in 1 minute, 5 minute, 10 minute, 30 minute, and 60 minute.

**Always on:** The monitor remains on unless the power button is pressed, short standby time.

1. Press the **MENU** button on the monitor, and select  > **Sleep Mode**.
2. Press LEFT and RIGHT direction buttons to select the options between Audio Off, Audio On and Always On, then press OK to proceed with the selection.
3. Press the DOWN, select the time length settings desired for the monitor to enter sleep mode in 1 minute, 5 minute, 10 minute, 30 minute, and 60 minute.
4. Press OK to save settings.

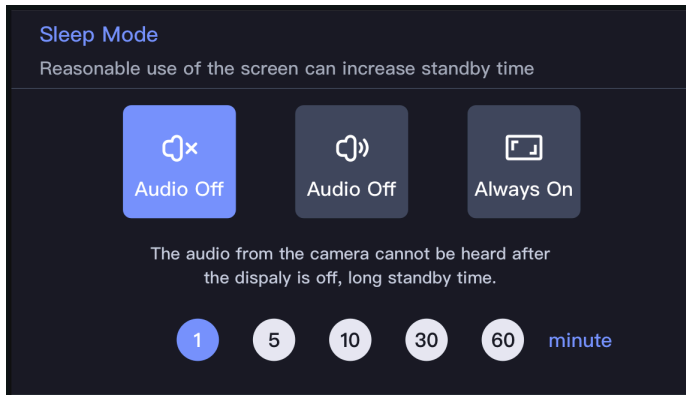

## Date and Time

Set the monitor to automatically enter sleep mode according to the length of time set to increase the monitor standby time. Any of the detection triggered will turn the LCD back on. If none of the detection is active, press the power button on the monitor to turn the LCD back on.

1. Press the **MENU** button on the monitor, and select  > **Date and Time**.
2. Press Direction buttons to change date, time and time displaying mode.
3. Press OK to save settings.

## Camera Light (Status Light / Night Light)

Set the camera status LED indicator on or off, and turn on night light if required or set the lighting mode or the light colour for the night light.

1. Press the **MENU** button on the monitor, and select  > **Light**.
2. Press UP and DOWN Direction buttons to select between Status light or Night light, and press OK to confirm selection.
3. Press direction buttons to select options or change settings.
4. Press OK to save settings

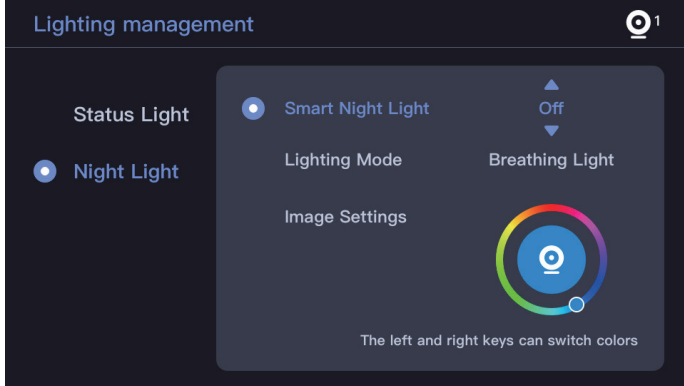

## SD Card

View the total capacity and the free space left in the micro SD Card if it is inserted to the monitor. The monitor only supports up to 128GB micro SD Card and only recognise fat32 type micro SD Card. You may format the SD Card as required and be sure to backup important files before formatting the micro SD Card. Camera SD Card slot is only for firmware updates.

1. Press the **MENU** button on the monitor, and select  > **SD Card Management**.
2. Press OK to format the micro SD Card.
3. Press LEFT and RIGHT direction buttons to change options between Yes or No and then press OK to proceed with the selection.

## Wallpaper

Set the wallpaper of the monitor from the system gallery or you may upload your preferred wallpaper to the micro SD card and select your favourite image as wallpaper. The supported format in the micro SD Card is jpeg.

1. Press the **MENU** button on the monitor, and select  > **Wallpaper**.
2. Press directional buttons to select your preferred wallpaper. Select “+” if you wish to choose the wallpaper from the micro SD Card.
3. Press LEFT and RIGHT direction buttons to select images, and then press OK to proceed with the selection.

## Language

Set the language of the monitor from the system, select your favourite language.

1. Press the **MENU** button on the monitor, and select  > **Language**.
2. Press directional buttons to select your preferred language.

## Factory Reset

This option allows you to restore your system to factory setting. The monitor will reboot, and all menu settings will be reset, requiring you to pair the camera with the monitor again.

1. Press the **MENU** button on the monitor, and select  > **Factory Reset**.
2. Press OK to reset the monitor.
3. Press LEFT and RIGHT direction buttons to change options between Yes or No and then press OK to proceed with the selection.

## Device Information

1. View the monitor and camera firmware version.
2. Press the **MENU** button on the monitor, and select  > **Device Information**.
3. Press LEFT and RIGHT direction buttons to toggle between the monitor and camera firmware information and whether there is an upgrade.

## Battery Information

Status (Monitor + Camera)	Time
Charing time	<ul style="list-style-type: none"><li>• 3.5 hours (Device On)</li><li>• 4.5 hours (Device Off)</li></ul>
Standby time (Screen On)	<ul style="list-style-type: none"><li>• 6-8 hours</li></ul>
Standby time (Screen Off)	<ul style="list-style-type: none"><li>• 3.5-5 days</li></ul>

## TROUBLESHOOTING

If you have problems with the system, there is often a quick and simple solution. Please try the following:

If	Try
There is no picture on the monitor from the camera	<ul style="list-style-type: none"> <li>• checking all connections to the camera. Make sure the adaptor is plugged in.</li> <li>• making sure that the cameras and monitor are both ON.</li> <li>• making sure that the camera is in range of the monitor.</li> </ul>
The picture keeps dropping on the monitor	<ul style="list-style-type: none"> <li>• moving the camera closer to the monitor.</li> <li>• repositioning the camera, monitor or both to improve the reception.</li> <li>• adjusting the monitor antenna to vertical position.</li> </ul>
There are audio problems	<ul style="list-style-type: none"> <li>• making sure that there is sound within range of the camera microphone.</li> <li>• moving the camera or monitor farther apart if the unit emits a loud screeching noise.</li> </ul>
There is an irregular beeping coming from the monitor	That is the Alert tone. Go to the Alert screen to turn the alert volume down or off .
The picture has become choppy	<p>The picture may become choppy when experiencing a lower frame rate. Try:</p> <ul style="list-style-type: none"> <li>• moving the camera closer to the monitor.</li> <li>• removing obstructions between the monitor and camera.</li> <li>• adjusting the monitor and antenna to vertical position.</li> </ul>
The monitor picture has frozen	Use the reset pin included to reset the monitor. The monitor turns off. Press <b>POWER</b> to turn it back on again.
You can't record video or take a snapshot	Ensure a micro SD Card is inserted and format the SD card with the system. The SD Card needs to be FAT32 format.

# SPECIFICATION

## CAMERA

Image Sensor	1/2.9" 2Megapixel Colour CMOS
Video Resolution	1920 x 1080p
Viewing Angle	100°
Two-way Audio	Yes
Night Vision	Up to 10m
Temperature Sensor	Yes
Humidity Sensor	Yes
Battery	3350mAh
Power Input	DC 5V/1A
Operating Temperature Range	0°C ~ 40°C
Operating Humidity Range	Within 90% Relative Humidity

## MONITOR

Display	4.3" LCD
Resolution	480 x 272p
Two-way Audio	Yes
Transmission Distance	Up to 200m line of sight
Storage	Supports up to 128GB micro SD Card
Battery	3000mAh
Power Input	DC 5V/1A Type-C
Operating Temperature Range	0°C ~ 40°C
Operating Humidity Range	Within 90% Relative Humidity





# TWO-YEAR LIMITED WARRANTY

## BW4501 Series

**IMPORTANT Satisfactory evidence of the original purchase is required for warranty service.** Please refer to our Uniden website for any details or warranty durations offered in addition to those contained below.

## Warrantor

The warrantor is Uniden Australia Pty Limited ABN 58 001 865 498 (“Uniden Aust”).

## Terms of Warranty

Uniden Aust warrants to the original retail purchaser only that the BW4501 (“the Product”), will be free from defects in materials and craftsmanship for the duration of the warranty period, subject to the limitations and exclusions set out below.

## Warranty Period

This warranty to the original retail purchaser is only valid in the original country of purchase for a Product first purchased either in Australia or New Zealand and will expire, as indicated below, from the date of original retail sale.

Product	2 Year
Accessories and Batteries	90 Days

If a warranty claim is made, this warranty will not apply if the Product is found by Uniden to be:

- (A) Damaged or not maintained in a reasonable manner or as recommended in the relevant Uniden Owner’s Manual;
- (B) Modified, altered or used as part of any conversion kits, subassemblies or any configurations not sold by Uniden Aust;
- (C) Improperly installed contrary to instructions contained in the relevant Owner’s Manual
- (D) Repaired by someone other than an authorized Uniden Repair Agent in relation to a defect or malfunction covered by this warranty; or
- (E) Used in conjunction with any equipment, parts or a system not manufactured by Uniden.

## Parts Covered

This warranty covers the Product and included accessories.

## **User-generated Data**

This warranty does not cover any claimed loss of or damage to user-generated data (including but without limitation phone numbers, addresses and images) that may be stored on your Product.

## **Statement of Remedy**

If the Product is found not to conform to this warranty as stated above, the Warrantor, at its discretion, will either repair the defect or replace the Product without any charge for parts or service. This warranty does not include any reimbursement or payment of any consequential damages claimed to arise from a Product's failure to comply with the warranty.

Our goods come with guarantees that cannot be excluded under the Australian Consumer Law. You are entitled to a replacement or refund for a major failure and for compensation for any other reasonably foreseeable loss or damage. You are also entitled to have the goods repaired or replaced if the goods fail to be of acceptable quality and the failure does not amount to a major failure.

This warranty is in addition to and sits alongside your rights under either the COMPETITION AND CONSUMER ACT 2010 (Australia) or the CONSUMER GUARANTEES ACT (New Zealand) as the case may be, none of which can be excluded.

## **Procedure for Obtaining Warranty Service**

Depending on the country in which the Product was first purchased, if you believe that your Product does not conform with this warranty, you should deliver the Product, together with satisfactory evidence of your original purchase (such as a legible copy of the sales docket) to Uniden. Please refer to the Uniden website for address details. You should contact Uniden regarding any compensation that may be payable for your expenses incurred in making a warranty claim. Prior to delivery, we recommend that you make a backup copy of any phone numbers, images or other data stored on your Product, in case it is lost or damaged during warranty service.

### **UNIDEN AUSTRALIA PTY LTD**

Phone number: 1300 366 895

Email address: [custservice@uniden.com.au](mailto:custservice@uniden.com.au)

**Uniden<sup>®</sup>**

© 2024 Uniden Australia Pty Limited.

V1.3